

# NGC-20-C-E and NGC-20-CL-E

nVent

RAYCHEM

CONNECT AND PROTECT

## Field-mounted Electronic heat-tracing control unit

### PRODUCT OVERVIEW

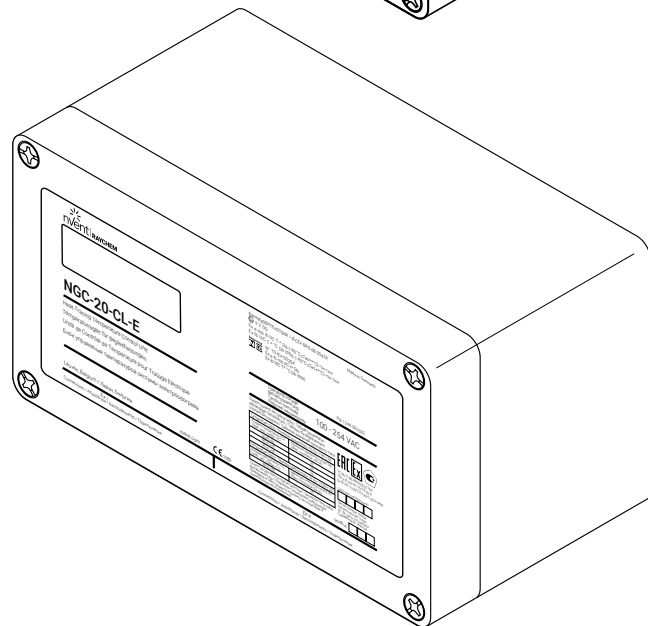
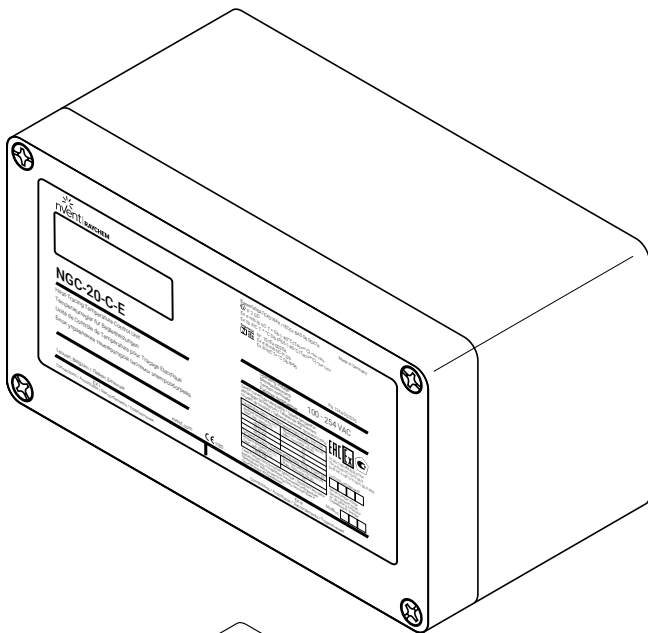

The nVent RAYCHEM NGC-20 is an electronic heat-tracing control unit featuring the benefits of local control and the capability for central monitoring. The NGC-20 control unit can be used for single phase circuits up to 25 A and is approved for use in hazardous areas. The NGC-20 can provide tight temperature control and is available with an IEC 61508-SIL 2 classified safety temperature limiter on board (NGC-20-CL-E). It measures the temperature with up to two RTD(s) connected to the unit. The Safety temperature limiter has a dedicated temperature input.

### CONTROL, MONITORING AND ALARM CAPABILITIES

The NGC-20 offers several different control algorithms including PASC for an optimised electrical heat-tracing control. The NGC-20 offers alarms for high and low temperature, high and low current, ground-fault current and voltage. The trip and warning level of the ground-fault current is user configurable and can be used as a warning and to isolate circuits. The NGC-20 control unit provides a dry contact relay for alarm annunciation.

### AUTOMATED HEAT-TRACING SYSTEM CHECK

To ensure system integrity the NGC-20 control unit can be configured to periodically check dormant heating cables for faults. As a consequence maintenance is systematically informed about the status of the heat-tracing system and unexpected and usually expensive downtime of important pipelines can be reduced.

### COMMUNICATIONS AND NETWORKING

The NGC-20 control unit is equipped with a RS-485 interface. Through this interface up to 247 NGC-20 units can be networked to a single nVent RAYCHEM NGC-UIT2 or to one serial port of standard PC running nVent RAYCHEM Supervisor software.

The NGC-20 control unit can as well be monitored and/or configured via the nVent RAYCHEM NGC-CMA wireless handheld device. This device is available for hazardous and non-hazardous areas.

### INSTALLATION

The NGC-20 control unit can be installed in the field near the heating application. The NGC-20 enclosures are manufactured from high impact-resistant, UV stabilized glass-filled polyester suitable for installation indoors or outdoors. One heating cable can be directly connected to the unit. The units can be mounted on the heated surface via an appropriate support bracket.

## CONFIGURATION AND COMMISSIONING

The NGC-20 control unit can be commissioned locally by means of a handheld programming device (nVent RAYCHEM NGC-CMA) or from a central location using the nVent RAYCHEM NGC-UIT or Supervisor Software. After programming, all settings are permanently stored in the non-volatile memory of the NGC-20 control unit, avoiding loss of data in the event of power failure or after a long term power shutdown. The NGC-20 control unit allows the heating and power cable to be connected directly to the unit.

## DIMENSIONS (IN MM)

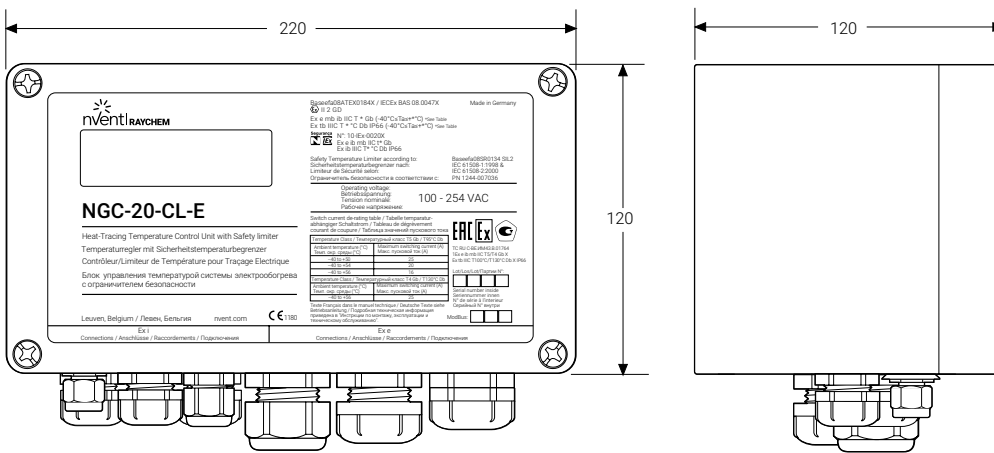

Sample shown is NGC-20-CL-E. Gland included in scope of delivery - 1 x M25 x 1,5

## GENERAL

Application type

**CE** nVent RAYCHEM NGC-20-C(L)-E units are approved for use in Hazardous area Zone 1 or Zone 2 (Gas) or Zone 21 or Zone 22 (Dust) and non hazardous areas

## APPROVALS

Baseefa08ATEX0184X / IEC Ex BAS 08.004 7X

II 2 GD

Ex e mb ib IIC T \* Gb (-40°C ≤ Ta ≤ +\*°C)

\*See Table

Ex tb IIIC T \* °C Db IP66 (-40°C ≤ Ta ≤ +\*°C)

\*See Table

**EAC Ex** EAЭC RU C-BE.AД07.B.04187/22  
 ООО «Центр Сертификации ВЕЛЕС»  
 1Ex e ib mb IIC T5/T4 Gb X  
 Ex tb IIIC T100°C/T130°C Db X IP66  
 -60°C < Tamb < 60°C

Segurança



Nº: 10-IEEx-0020X

Ex e ib mb IIC T\* Gb

Ex td IIIC T\* °C Db IP66



T\*: The switching capacity depends on the hazardous area temperature classification (T-Class) and the maximum expected use temperature. Ratings as shown in table below

Temperature Class T5		Temperature Class T4	
Maximum Ambient Temperature	Maximum Switching Current	Maximum Ambient Temperature	Maximum Switching Current
+50°C	25 A	Up to 56°C	25 A
+54°C	20 A		
+56°C	16 A		

All values as per hazardous area certification.

Current ratings are given for a supply voltage of 254 V +/-10%, 50/60 Hz and resistive loads only.

## FUNCTIONAL SAFETY APPROVAL



Baseefa08SR0134 SIL2  
 IEC 61508-1:1998 & IEC 61508-2:2000

Conditions of Safe Use

Refer to Hazardous Area Certificate or installation instructions

## ENVIRONMENTAL

Temperature range control unit	From -200°C to +700°C in steps of 1K
Temperature range limiter	From -60°C to +599°C in steps of 1K (NGC-20-CL-E only)
Ambient operating temperature	From -40°C to +56°C (ATEX, IEC Ex)
Storage temperature	From -55°C to +80°C (ATEX, IEC Ex)

## ENCLOSURE

	The NGC-20-C(L)-E units can be installed directly on the pipe via an appropriate support bracket as long as the maximum permitted ambient temperature is not exceeded. Alternatively, units can be mounted on any stable structure via the moulded holes in the enclosure.
Protection	IP 66 per IEC-60529
Material	Glass fibre reinforced enclosure with internal earth plate on the bottom
Entries	3 x M25 1 x M25 gland Ø 8 – 17 mm: power IN/heating cable out 1 x M25 stopping plug: daisy chaining of power 1 x M25 rain plug: daisy chaining of power
	3 x M20 Digital communication IN/OUT and alarm (all with stopping plugs)
	2 X M16 Temperature sensor(s) 1 with stopping plug one with rain plug
Mounting & installation	Installation on an appropriate support bracket directly on the heated surface up to temperatures of 230°C. When the temperature of the heated surface is above 230°C, install the control unit to a stable structure nearby the application.
Installation position	Any position allowed, typical use with glands facing down

1 EC-61508 Safety related information is published in the NGC-20 installation instructions INSTALL-130. A copy of the INSTALL-130 can be downloaded from the literature section on [salesthermaluk@nvent.com](mailto:salesthermaluk@nvent.com) or can be obtained via your local nVent representative.

## ELECTRICAL DATA

Power supply & own power consumption	100 Vac to 254 Vac +/-10 % 50/60 Hz 20 VA max.
Connection terminals	Spring-type
L, N and PE terminals	9 pc (cables with cross section ranging from 0.2 to 6 mm <sup>2</sup> )
Alarm output terminals	3 pc (cables with cross section ranging from 0.2 to 2.5 mm <sup>2</sup> )
Pt 100 (RTD) terminals	12 pc (cables with cross section ranging from 0.2 to 1.5 mm <sup>2</sup> )
RS-485 communication	7 pc (0.2 to 1.5 mm <sup>2</sup> )
Internal Earth stud for RTD shield	1 pc (Cable cross section max 6 mm <sup>2</sup> )
Contact lifetime main switch	500k operations at 25 A/250 Vac (resistive load)
Alarm output relay	Contact rated 250 Vac/3 A Relay output is software programmable to open, close or to toggle in case of alarm
Electromagnetic compatibility	EN 61000-6-2:2005 (Gen. Immunity standard for industrial environments) EN 61000-6-3:2007 (Gen. Emission standard for residential, commercial and light industrial) EN 61000-3-2-2006 (Limits for harmonic current emissions) EN 61000-3-3:1995+A1:2001+A2:2005 (limitation of voltage fluctuations and flicker)
Electrical safety	EN 61010-1, Category III, Pollution degree 2
Vibration & Shock	Shock to EN 60068-2-27: 1/2 sine wave of 11 ms duration, 15 g Vibration to EN 60068-2-6/sine wave 10 to 150 Hz (p-p), 2 g

## TEMPERATURE SENSORS

Compatible types	100 Ω platinum, 3-wire, $\alpha = 0.00385 \Omega/^{\circ}\text{C}$ . Can be extended with a three core shielded or braided cable of maximum 20 Ω lead resistance per conductor.
Quantity	Two RTD inputs for the control unit plus one independent temperature input for the safety limiter. All temperature sensors are permanently monitored for "sensor short", "sensor break".

## COMMUNICATIONS

Physical network	RS-485 and Bluetooth Class 1
Protocol/topology	Modbus RTU or ASCII. Multi drop/Daisy chain
Cable and maximum length	Shielded twisted pair cable, 0.5 mm <sup>2</sup> (AWG 24) or larger maximum cable length between should be no more than 1200 m
Maximum quantity of control units in one network	Max. of 247 units per nVent RAYCHEM NGC-UIT or per serial communication port
(Modbus) Network address	Software programmable via nVent RAYCHEM NGC-CMA2-ZONE 1, nVent RAYCHEM NGC-CMA2-ZONE 2 or Supervisor

## PROGRAMMING AND SETTING

Method	Through handheld programming device NGC-CMA2-ZONE 1, NGC-CMA2-ZONE 2 (hazardous area) and a wireless Bluetooth connection or via RS485 interface and Supervisor software or nVent RAYCHEM User Interface Terminal (NGC-UIT2-ORD) and nVent RAYCHEM software.
Units of measure	°C or °F, software selectable
Memory	Non-volatile, no loss of parameters after the event of power outage or long term shut down, data holding time ~10 years.
LED indicators	Status LEDs are available for:
NGC-20-C-E	Heater, Alarm, RS-485 communication, Bluetooth communication
NGC-20-CL-E	Heater, Alarm, Limiter Tripped, RS-485 communication and Bluetooth

## MEASURING RANGES

Temperature range control unit	From -200°C to +700°C in steps of 1K
Temperature range limiter	From -60°C to +599°C in steps of 1K (NGC-20-CL-E only)
Voltage	From 50 Vac to 305 Vac
Load Current	From 0.3 A to 30 A
Ground-fault current	From 10 mA to 250 mA (RCD/ELCB required due to IEC and/or local regulations)
Heater time alarm	From 1 to 1 x 10 <sup>6</sup> hours
Relay cycle alarm	From 0 to 2 x 10 <sup>6</sup> cycl

## Ordering information

### NVENT RAYCHEM NGC-20 CONTROL UNITS

Name	Description	Part number	Approvals	Weight
NGC-20-C-E	Controller	1244-007035	ATEX, IEC Ex, Seguranca, EAC Ex, metrology certificate Russia	2.2 kg
NGC-20-CL-E	Controller + Limiter	1244-007036	ATEX, IEC Ex, Seguranca, EAC Ex, metrology certificate Russia	2.3 kg
NGC-20-C-E (for Russia)	Controller	1244-018772	EAC Ex, metrology certificate Russia	2.2 kg
NGC-20-CL-E (for Russia)	Controller + Limiter	1244-018773	EAC Ex, metrology certificate Russia SIL2 limiter	2.3 kg

## TEMPERATURE SENSORS

Product name	MONI-PT100-260/2 or MONI-PT100-EXE-SENSOR
--------------	---

### SUPPORT BRACKET FOR INSTALLATION ON PIPE

Product name	SB-125
Part number & (weight)	1244-06603 (0.5 kg)

### BLUETOOTH ENABLED HANDHELD PROGRAMMING DEVICE WITH CUSTOMIZED NVENT RAYCHEM SOFTWARE

Product name	NGC-CMA2-ZONE1 (Hazardous area approved device for use in Zone 1, 21)
Part number & (weight)	1244-018988 (1.25 kg)
Product name	NGC-CMA2-ZONE2 (Hazardous area approved device for use in Zone 2, 22)
Part number & (weight)	1244-006606 (0.6 kg)

**CONNECTION DIAGRAM (TYPICAL)**

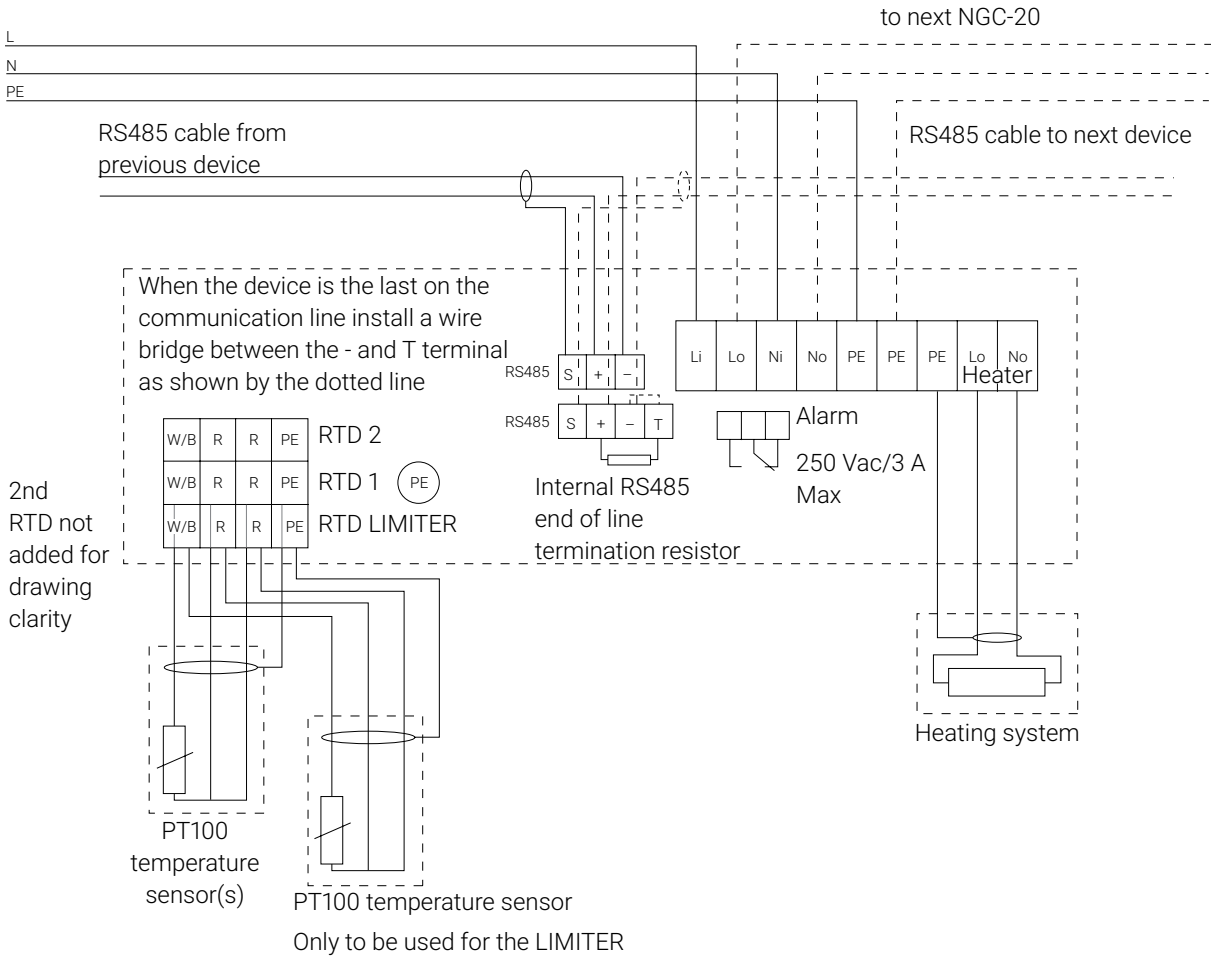

**North America**

Tel +1.800.545.6258  
 Fax +1.800.527.5703  
 thermal.info@nVent.com

**Europe, Middle East, Africa**

Tel +32.16.213.502  
 Fax +32.16.213.604  
 thermal.info@nVent.com

**Asia Pacific**

Tel +86.21.2412.1688  
 Fax +86.21.5426.3167  
 cn.thermal.info@nVent.com

**Latin America**

Tel +1.713.868.4800  
 Fax +1.713.868.2333  
 thermal.info@nVent.com



Our powerful portfolio of brands:

**CADDY ERICO HOFFMAN RAYCHEM SCHROFF TRACER**