

HEAT-TRACING REMOTE MONITORING MODULE

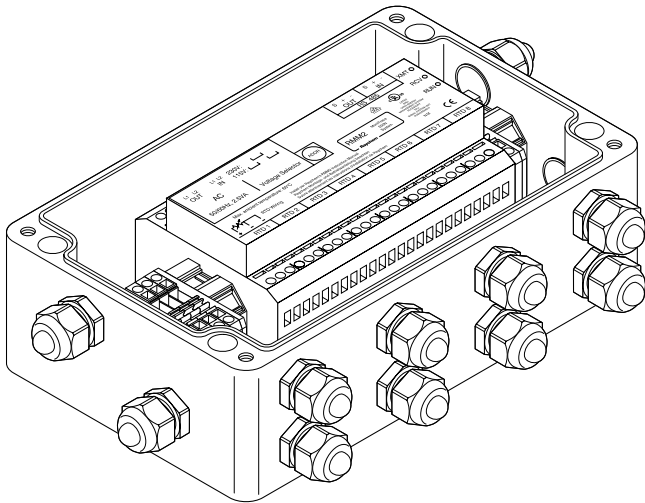

The Remote Monitoring Modules (RMM2) provide temperature monitoring capability for nVent RAYCHEM NGC controller family. The RMM2 accepts inputs from up to eight Pt 100 temperature sensors that measure pipe or ambient temperatures in a heat-tracing system. Multiple RMM2 units communicate with a single nVent RAYCHEM NGC User Interface Terminal (nVent RAYCHEM NGC-UIT) providing centralised monitoring of temperatures.

A single, twisted pair RS-485 cable connects up to 16 RMMs for a total monitoring capacity of 128 temperatures per nVent RAYCHEM NGC controller network.

CONTROL AND MONITORING

An nVent RAYCHEM NGC network controls up to 260 circuits of heat-tracing per system based on ambient or pipe temperatures. The RMM2 may be used to collect both ambient and pipe temperatures for control or for extensive monitoring of the heat-tracing system. The RMM2 units are placed near desired monitoring locations, even in hazardous areas (Zone 2). Multiple temperature sensor inputs are networked over a single cable, significantly reducing installation cost for temperature monitoring.

ALARMS

Low and high temperature alarms may be set for sensors connected to the nVent RAYCHEM NGC controllers via the RMM2. Alarm limits are set and alarm conditions are reported to the user. Additional alarms are triggered for failed temperature sensors and communication errors. Alarms may be reported remotely through an alarm relay in the nVent RAYCHEM NGC-UIT or via nVent RAYCHEM Supervisor.

CONFIGURATIONS

The RMM2 is an electronic device that clips to a DIN 35 rail. The complete kit for ordinary and hazardous areas (Zone 2) include an RMM2 mounted in a rugged polyester enclosure with appropriate terminals and cable glands. For other installation options, contact nVent.

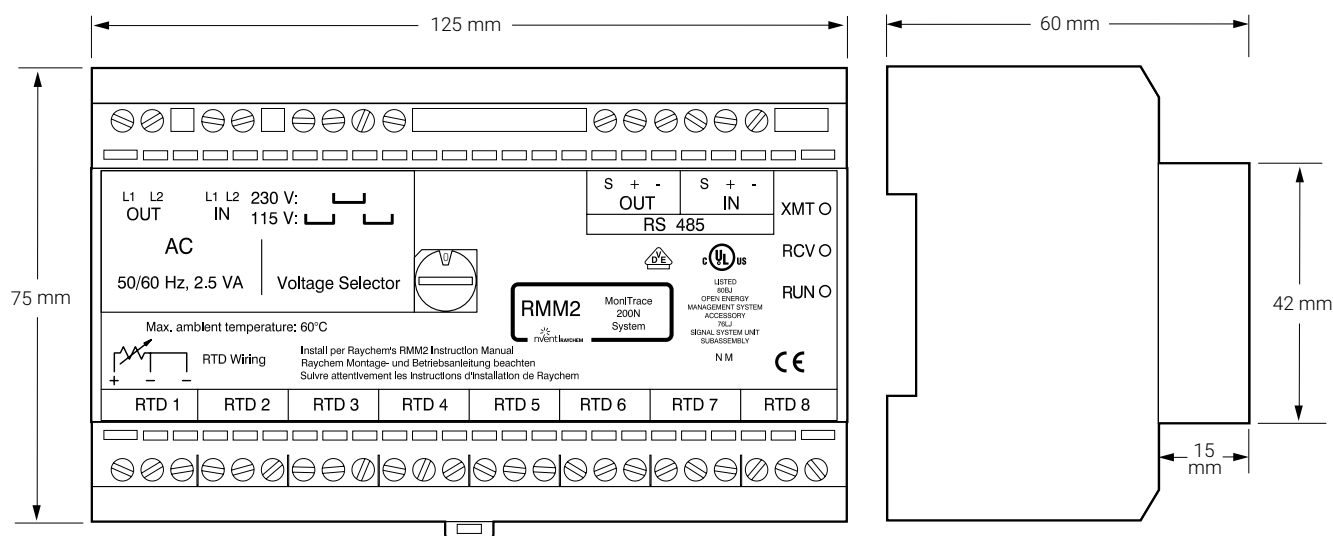
DIMENSIONS (IN MM)**GENERAL**

Area of use	Hazardous area (Zone 2) or non-hazardous area RMM2-EX-E hazardous area zone 2 or non-hazardous area RMM2-E panel mount, safe area
-------------	---

APPROVALS

RMM2-EX-E only:	Baseefa03ATEX0739X II 3GD T70°C EEx nR II T6 (-20°C ≤ Ta ≤ 60°C)
-----------------	---

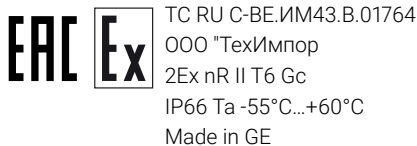

Ambient operating temperature range	-40°C to +60°C
Ambient storage temperature range	-51°C to +60°C
Relative humidity	max. 95%, noncondensing
Supply voltage (nominal)	115/230 Vac +10% -10% 50/60 Hz (jumper selectable)
Internal power consumption	3 VA

RMM2 Hazardous Area Enclosure	nVent RAYCHEM MONI-RMM2-EX-E
Protection	IP66
Base and lid	Material: glassfibre-reinforced polyester, lid seal: silicone
Colour	Black
Ambient temperature range	-20°C to +60°C
Lid fixing	4 x M6, cheese-head, captive, stainless steel
Entries	12 x M20 for cable diameters ranging from 6 to 12 mm
Glands provided (EEx e)	12 x M20 with integral stopping plugs
Mounting	Surface mounting with 4 fixing holes on 240 x 110 mm centres hole diameter: 5 mm

TEMPERATURE SENSORS

Type	3 wire Pt 100, temperature coefficient per IEC 751-1983
Quantity to be connected	Up to 8 Pt 100 per RMM2 The sensor cable may be extended with a 3 (+PE)-wire signal cable adding 20 Ohms lead resistance maximum. When using 1.5 mm ² cable this equals to ±150 m of cable. When the sensor cable is laid in cable ducts or in the vicinity of highvoltage carrying cables the sensor extension cable should be shielded. The shield of the extension cable should be grounded at the controller end only.

Area of use	Use sensors with the appropriate approvals required for the area of use
-------------	---

ENCLOSURE DETAILS - HAZARDOUS AREA ENCLOSURE RMM2-EX-E

DIMENSIONS (IN MM)

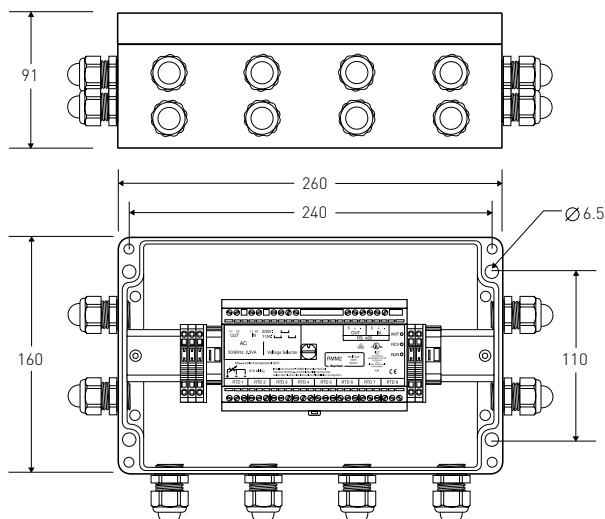

COMMUNICATION TO NGC-30-UIT NVENT RAYCHEM NGC CONTROLLERS

Type	RS-485
Cable	1 shielded twisted pair
Length	1200 m max.
Quantity	Up to 16 RMM2 UIT per nVent RAYCHEM NGC network
Address	Switch-selectable on RMM2

CONNECTION TERMINALS

Supply (in-out)	4 terminals for cables 0.2 mm ² to 4 mm ²
Earth	10 terminals for cables up to 4 mm ² aside the RMM2 unit
Pt 100 connections	8 x 3 terminals for cables 0.2 mm ² to 2.5 mm ²
RS-485 connection	2 x 3 terminals for cables 0.2 mm ² to 2.5 mm ²

ELECTROMAGNETIC COMPATIBILITY

Immunity	Complies with EN 50 082-2 (heavy industrial)
Emissions	Complies with EN 50 081-1 (light industrial)

ORDERING DETAILS

RMM2	Part descriptions	Product Number	Weight
No enclosure, internal electronics module only	RMM2-E	307988-000	1.2 kg
With hazardous area enclosure	RMM2-EX-E	676040-000	3.2 kg

Pipe temperature sensors (Pt 100)

Pt 100 temperature sensor for Zone 1	MONI-PT100-EXE	967094-000	0.6 kg
Pt 100 temperature sensor for ordinary areas	MONI-PT100-NH	140910-000	0.2 kg

North America

Tel +1.800.545.6258
Fax +1.800.527.5703
thermal.info@nVent.com

Europe, Middle East, Africa

Tel +32.16.213.502
Fax +32.16.213.604
thermal.info@nVent.com

Asia Pacific

Tel +86.21.2412.1688
Fax +86.21.5426.3167
cn.thermal.info@nVent.com

Latin America

Tel +1.713.868.4800
Fax +1.713.868.2333
thermal.info@nVent.com



nVent.com

Our powerful portfolio of brands:

CADDY ERICO HOFFMAN RAYCHEM SCHROFF TRACER